

FAST-LOCK COUPLING SYSTEM F30 COUPLING SOCKET FVK30

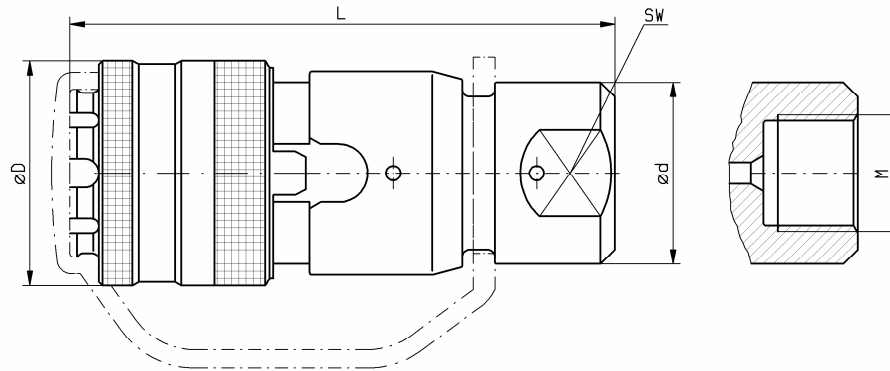

TECHNICAL DATA:

Article number	1-06000-0001	1-06000-0003
connection	female thread	
Sealing method	60° cone	
thread size	M16x1,5	M20x1,5
hexagon SW	22 mm	27 mm
max. thight. torque	40 Nm	70 Nm
length L	75 mm	78,5 mm
diameter D	31 mm	
diameter d	25 mm	30 mm
coupling stroke	20 ⁺¹ mm	
weight	0,27 kg	0,3 kg

Further designs and connections are available upon request.
General technical data see summary data sheet 1-06000

ORDER DENOMINATION:

„Fast-Lock coupling socket FVK30, *Art.-Nr. 1-06000-XXXX*“

The last 4 digits define connection type and size e.g. M16x1,5 IG: 1-06000-0001.

DELIVERY STATE:

Completely assembled and tested, incl. dust cap

The Fast-Lock coupling sockets are made for use with hydraulic oil. Please ask for other fluids.

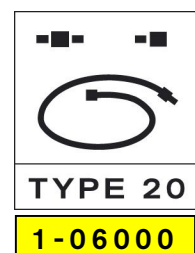

FASTEC AG
INDUSTRIEZONE
SCHÄCHENWALD
CH-6460 ALTDORF
SWITZERLAND

FON +41 41 875 78 30
FAX +41 41 875 78 31
INFO@FASTEC.CH
WWW.FASTEC.CH